

## Fiber Optic SFP DFB 2.67G CWDM Transceiver with DDMI

Data Sheet

**OFD3556-XX**



The OFD3556-XX transceiver module operates at wavelengths of 1470-1610 nm and at 2.67 Gb/s for CWDM, OC-3, OC-12 and OC-48 intermediate reach applications.

### Features

- Hot-pluggable
- Single +3.3 V supply
- Duplex LC connector interface
- CWDM Distributed Feedback LD
- Low power dissipation
- OC-48/STM-16 Intermediate Reach
- 40 km link distance
- Multi data rates from 100Mbps to 2.7Gbps
- Operates in wavelengths of 1470/1490/1510/1530/1550/1570/1590/1610nm
- Internal Digital Diagnostics calibration
- Digital Diagnostics Monitoring for SFF-8472 compatible
- Multi-Source Agreement (MSA) for Small Form Factor Pluggable (SFP) Compliant

### Applications

- Telecommunications and Data Communications system networks
- SONET OC-12, OC-48 IR-2/STM S16.2
- SONET OC-3
- Gigabit Ethernet
- Point-to-Point networking
- Metro Access Rings
- 1x/ 2x Fiber Channel
- 100Base Fast Ethernet

### Description

The OFD3556-XX transceiver provides signal conversion and processing for serial optical data communication applications. It operates over single mode fiber by converting lightwave information over specific wavelengths from 1470-1610nm into an electrical signal and vice versa at a data rate of 2.67 Gb/s.

Housed in a compact metal package, the transceiver module consists of a transmitter and receiver optical subassembly coupled with a duplex LC receptacle. A high-speed uncooled DFB laser diode operates as light source while a photodiode subsequently acts as a detector.

This dual-fiber connector transceiver is designed for use at 2.67 Gb/s in CWDM, SONET OC-3, OC-12, OC-48 IR-2/SDH STM-16 S16.2, Fast Ethernet, Gigabit Ethernet and 1x/2x Fiber Channel applications.

**Transceiver Monitoring Interface**

OFD3556-XX provides an enhanced monitoring interface, which allows real-time access to device operating parameters such as transceiver temperature, laser bias current, transmitted optical power, received optical power and transceiver supply voltage. It also defines a sophisticated system of alarm and warning flags, which alerts end-users when particular operating parameters are outside of a normal factory-set range. The monitoring interface makes use of two wire address 1010001X (A2h) and is backward compatible with the Small Form Pluggable Multi-Source Agreement (SFP MSA).

**Serial Identification (EEPROM)**

An SFP having module definition 4 provides access to sophisticated identification information that describes the SFP transceiver’s capabilities, standard interface, manufacturer and other information. An EEPROM containing the detailed product information and digital diagnostic function for the host equipment is accessed by the 2-wire serial CMOS EEPROM protocol. See SFP MSA for detailed description.

**Performance Specifications**

**Absolute Maximum Ratings**

Stresses in excess of the absolute maximum ratings can cause damage to the optical device. Operations of the optical device are suggested to remain within the recommended operating conditions. Exposure to the absolute maximum ratings for extended periods can adversely affect device reliability.

Parameter	Symbol	Minimum	Maximum	Unit
Storage Temperature	T <sub>S</sub>	-40	+85	°C
Supply Voltage	V <sub>CC</sub>	0	4.0	V
Relative Humidity	RH	5	85	%

**Recommended Operating Conditions**

Parameter	Symbol	Minimum	Typical	Maximum	Unit
Operating Temperature	T <sub>OP</sub>	0		70	°C
Supply Voltage	V <sub>CC</sub>	3.1	3.3	3.5	V
Supply Current	I <sub>TX</sub> + I <sub>RX</sub>		200	300	mA

**Safety**

**Laser Compliance Statement**

The OFD3556-XX is classified as a Class I Laser Product and complies with IEC 60825-1 and FDA 21 CFR 1040.10 and 1040.11. The transceiver must be operated under recommended operating conditions. Because the transceiver is designed to be inherently eye safe, it does not require open fiber control thus eliminating complex electronics or mechanics.

Caution - use of device other than those specified herein may result in hazardous laser radiation exposure or other damage. Please embrace all customary precautions and discretion while handling this device.

**Transmitter Electro-Optical Interface (T<sub>C</sub> = 0~70°C; V<sub>CC</sub>T,R = 3.1V < V<sub>CC</sub> < 3.5V)**

Parameter	Symbol	Minimum	Typical	Maximum	Unit
Transmitter Differential Input Voltage	TD +/-	400		2000	mVp-p
Optical Output Power <sup>1</sup>	P <sub>O</sub>	0		+5	dBm
Optical Extinction Ratio <sup>1</sup>	E <sub>R</sub>	8.2			dB
Center Wavelength <sup>1</sup>	λ <sub>C</sub>	λ <sub>C</sub> -6	λ <sub>C</sub>	λ <sub>C</sub> +7	nm
Spectral Width <sup>1</sup>	Δλ			< 1	nm
Side Mode Suppression Ratio <sup>1</sup>	SMSR	30			dB
Optical Rise/ Fall Time <sup>2</sup>	t <sub>r</sub> / t <sub>f</sub>			0.15	nsec
Tx_Fault - HIGH	V <sub>Fault_H</sub>	2		V <sub>CC</sub>	V
Tx_Fault - LOW	V <sub>Fault_L</sub>	V <sub>ee</sub>		V <sub>ee</sub> + 0.5	V
Tx_Disable - High	V <sub>Disable_H</sub>	2		V <sub>CC</sub>	V
Tx_Disable - LOW	V <sub>Disable_L</sub>	V <sub>ee</sub>		V <sub>ee</sub> + 0.8	V

**Note:**

1. Measured at 2488.32 Mbps, PRBS 2<sup>23</sup>-1, NRZ.
2. 20%-80%

**Receiver Electro-Optical Specifications (T<sub>C</sub> = 0~70°C; V<sub>CC</sub>T,R = 3.1V < V<sub>CC</sub> < 3.5V)**

Parameter	Symbol	Minimum	Typical	Maximum	Unit
Receiver Differential Output Voltage	RD +/-	600	800		mVp-p
Receiver Overload <sup>1,2</sup>	P <sub>IN</sub> MAX	-8			dBm
Receiver Sensitivity <sup>1,2</sup>	P <sub>IN</sub> MAX			-18	dBm
Operating Center Wavelength	λ <sub>C</sub>	1270		1620	nm
Receiver LOS Assert Level <sup>2</sup>	P <sub>RX_LOS A</sub>	-33			dBm
Receiver LOS Deassert Level <sup>2</sup>	P <sub>RX_LOS D</sub>			-18.5	dBm
Receiver Loss of Signal Hysteresis <sup>2</sup>		0.5	2		dB

**Note:**

1. With BER better than or equal to 1x10<sup>-12</sup>.
2. Measured in center of eye opening with 2<sup>23</sup>-1 PRBS, NRZ.

**Pin Assignment**

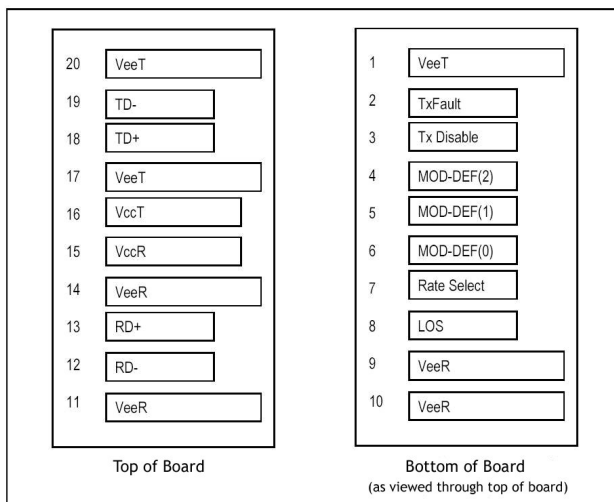

Figure 1. SFP Transceiver Electric Pad Layout

**OFD3556-XX SFP TRANSCEIVER DATA SHEET**

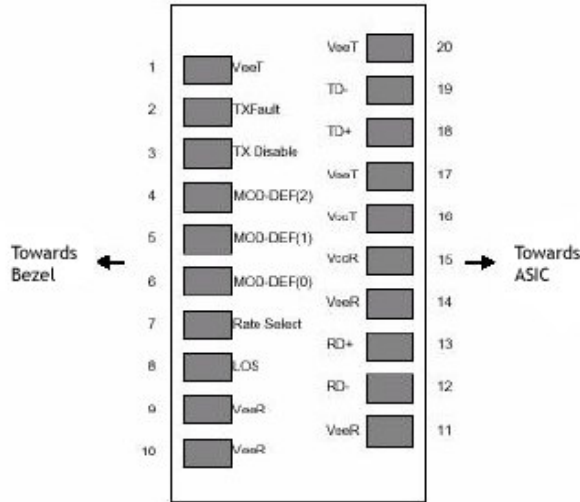

Figure 2. Diagram of Host Board Connector Block Pin

**Pin Description and Plug-in Sequence<sup>1</sup> (1-Grd, 2-Power, 3-Signal)**

Pin No.	Name	Description	Plug-in Sequence	Notes
1	VeeT	Transmitter Ground	1	Circuit ground is internally isolated from chassis ground.
2	TX Fault	Transmitter Fault Indication	3	Open-Collector outputs, asserted when LD and/or APC function fail.
3	TX Disable	Transmitter Disable	3	Disable when high voltage (>2.0V or Open).
4	MOD-DEF 2	Module Definition 2	3	Should be pulled up with 4.7k - 10 kΩ on host board to voltage between 2.0V and 5.5V. MOD-DEF (0) pulls line low to indicate module is plugged in.
5	MOD-DEF 1	Module Definition 1	3	See notes for Pin 4.
6	MOD-DEF 0	Module Definition 0	3	See notes for Pin 4.
7	Rate Select	Bandwidth Selection	3	No connection required.
8	LOS	Loss of Signal	3	LOS is Open-Collector output. Should be pulled up with 4.7k - 10kΩ on host board to a voltage between 2.0V and 5.5V. Logic 0 indicates normal operation; logic 1 indicates loss of signal.
9	VeeR	Receiver Ground	1	See notes for Pin 1.
10	VeeR	Receiver Ground	1	See notes for Pin 1.
11	VeeR	Receiver Ground	1	See notes for Pin 1.
12	RD-	Inv. Received Data Out	3	
13	RD+	Received Data Out	3	
14	VeeR	Receiver Ground	1	See notes for Pin 1.
15	VccR	Receiver Power	2	
16	VccT	Transmitter Power	2	

**OFD3556-XX SFP TRANSCEIVER DATA SHEET**

17	VeeT	Transmitter Ground	1	See notes for Pin 1.
18	TD+	Transmit Data In	3	
19	TD-	Inv. Transmit Data In	3	
20	VeeT	Transmitter Ground	1	See notes for Pin 1.

**Note:**

1. Pin engagement sequence during hot plugging.

**Physical Characteristics**

**Outline Diagram**

Dimensions for the device package are given in millimeters.

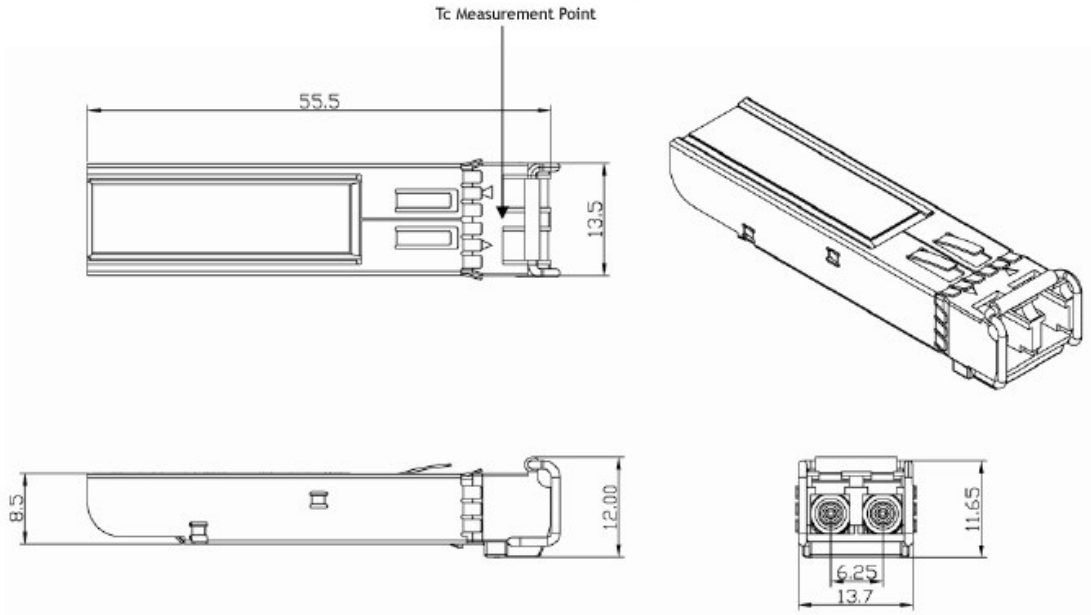



**OFD3556-XX SFP TRANSCEIVER DATA SHEET**

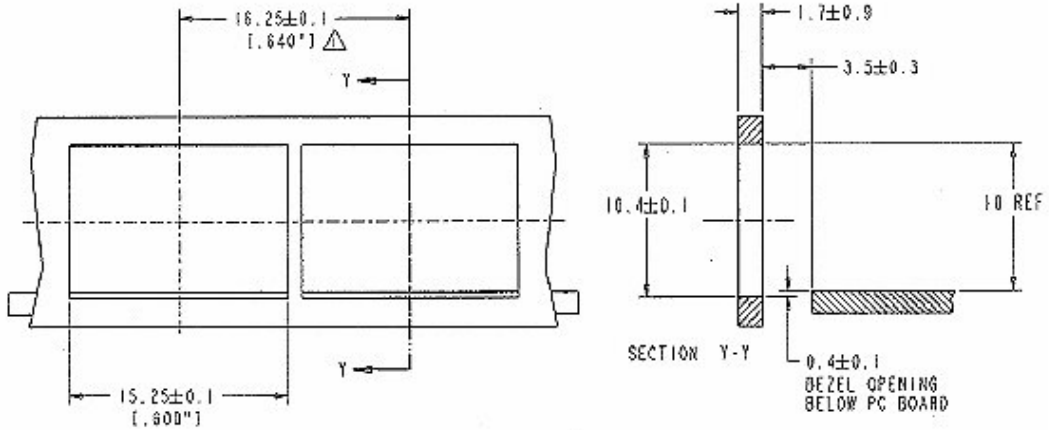
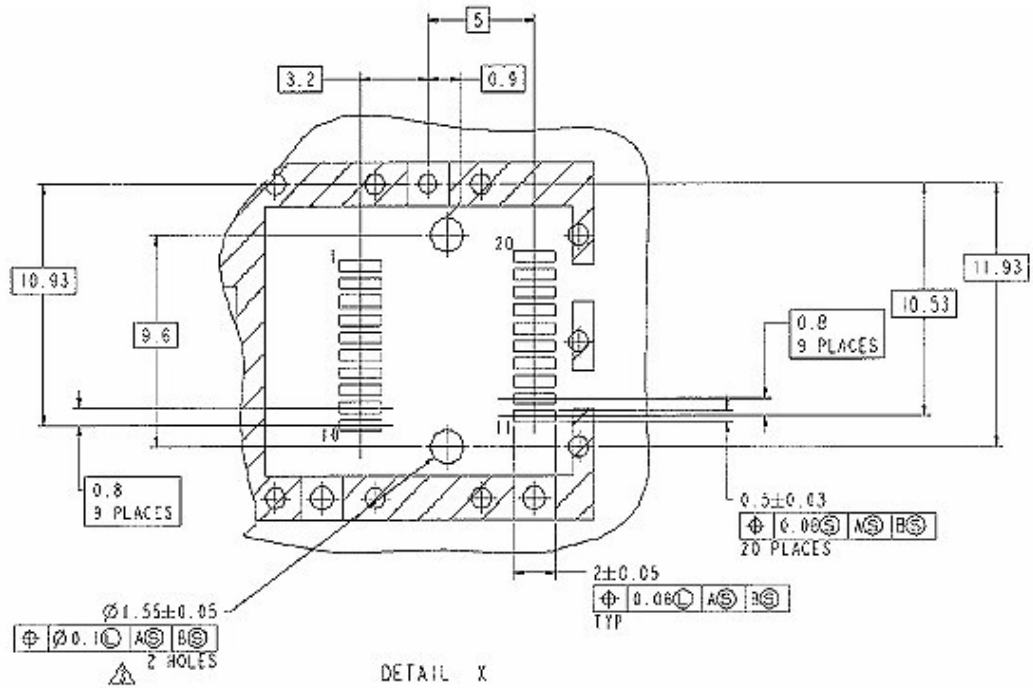

**NOTES:**

1. MINIMUM PITCH ILLUSTRATED, ENGLISH DIMENSIONS ARE FOR REFERENCE ONLY
2. NOT RECOMMENDED FOR PCI EXPANSION CARD APPLICATIONS

Application Circuits

Recommended Host Board Supply Filtering Network

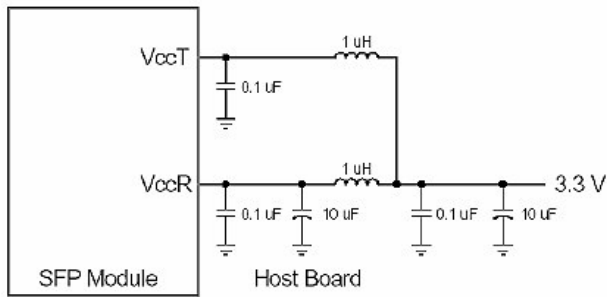

Recommended Interface Diagram

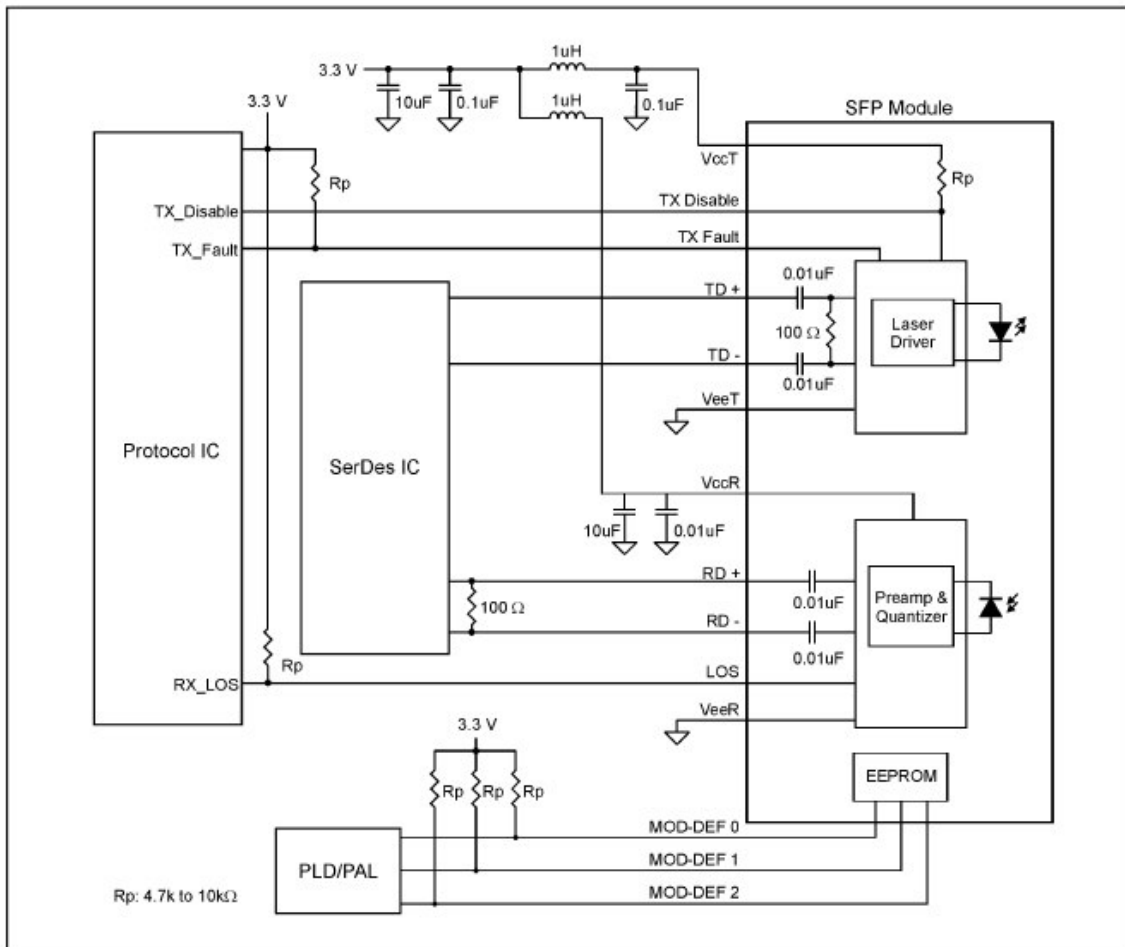

**Additional Information**

**Ordering Information**

Center Wavelength	Part Number
1470 nm	OFD3556-47
1490 nm	OFD3556-49
1510 nm	OFD3556-51
1530 nm	OFD3556-53
1550 nm	OFD3556-55
1570 nm	OFD3556-57
1590 nm	OFD3556-59
1610 nm	OFD3556-61

**Contact**

For additional information, product specifications, or information about Optocom:

Internet: <http://www.optocom.com>  
Email: [sales@optocom.com](mailto:sales@optocom.com)  
Tel: +1 978 988 8711  
Fax: +1 978 988 8722

©2005 Optocom Corporation. All rights reserved. Information in this document is believed to be accurate and reliable and is subject to change without notice. Optocom Corporation will not be held liable for technical or editorial errors or omissions contained herein. Reproduction in whole or in part is prohibited without prior written consent of the copyright owner and no responsibility will be assumed by Optocom Corporation for any infringements of third parties. All other brand or product names mentioned are the trademarks or registered trademarks owned by their respective companies or organizations.